



## Shifter Cable Lockdown For 10<sup>th</sup> Gen Civic

2018-05-10

AHP-INR-018

Thank you for purchasing this ALTA product for your car! Installation of this product should only be performed by persons experienced with installation of aftermarket performance parts and proper operation of high performance vehicles. If vehicle needs to be raised off the ground for installation, the installer must use proper jacks, jack-stands and/or a professional vehicle hoist for safety of the installer and to protect property. If the vehicle is lifted improperly, serious injury or death may occur! Please read through all instructions before performing any portion of installation. If you have any questions, please contact our tech department prior to starting installation. We can be reached in any of the following methods:

Email [Tech@ALTAperformance.com](mailto:Tech@ALTAperformance.com)

Instant Chat off the main page of [www.ALTAperformance.com](http://www.ALTAperformance.com)

Or simply call our tech team at 503-693-1702

### GENERAL MODIFICATION NOTE

Modifications to any vehicle can change the handling and performance. As with any vehicle extreme care must be used to prevent loss of control or roll-over during sharp turns or abrupt maneuvers. Always wear seat belts, and drive safely, recognizing that reduced speeds and specialized driving techniques may be required. Failure to drive a vehicle safely may result in serious injury or death. Do not drive a vehicle unless you are familiar with its unique handling characteristics and are confident of your ability to maintain control under all driving conditions. Some modifications (and combinations of modifications) are not recommended and may not be permitted in your state or country. Consult the owner's manual, service manual, instructions accompanying these products, and local laws before purchasing and installing these modifications. You are responsible for the legality and safety of the vehicle you modify using these components.

### Parts Included with the ALTA Shifter Cable Lockdown:

- (1) Shifter Cable Lockdown
- (6) O-Rings
- (1) Thread Locking Compound
- (5) Set Screws (Installed into part)
- (1) Hex Key



### Instructions:

- 1) Remove rear portion of center console by pulling straight back as shown above. This does require a decent amount of force to remove.
- 2) Locate and unplug (unscrewing may be easier) tire pressure monitor sensor mounted to the back of the console behind pan removed in step above.
- 3) Remove (2) screws from rear of inside of center console located under the arm rest.
- 4) Remove shift knob from car by pulling down boot to expose (2) clips. Carefully pry clips away from shifter while pushing down on boot to free boot, then hold knob and use 12mm wrench to unscrew nut. Remove knob from car.

Use Pick Tool Behind Shift Boot  
And Pry Clips Away From Rod  
And Pull Boot Down



Hold Knob And...

Unscrew Boot Holder  
With Wrench



- 5) Locate side plastic panels and pull them straight out as shown. These panels are difficult to remove and having proper panel removal tool will aid in removing them without causing damage.

Pull Both Sides  
Of Console Off

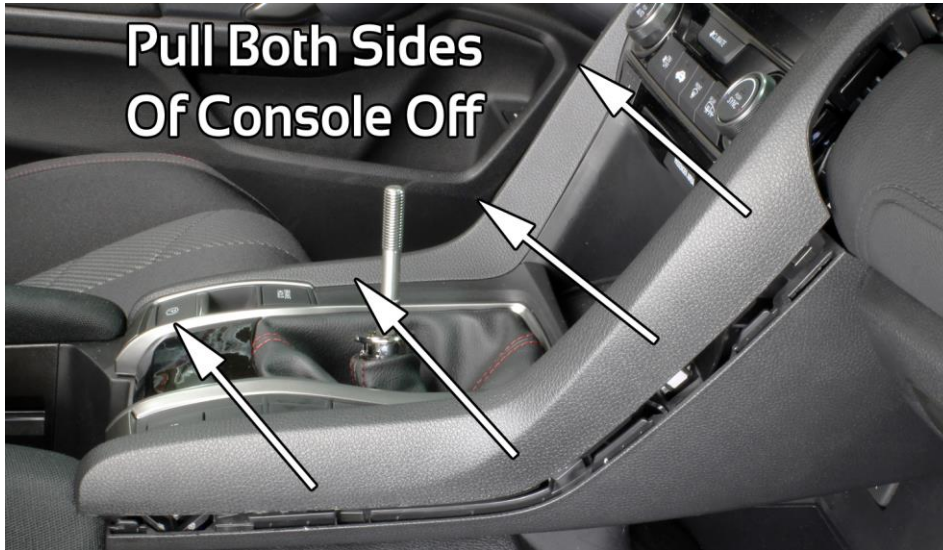

- 6) Remove (2) screws on each side of shift boot trim ring.  
7) Remove HVAC panel and remove (2) screws behind it.

Pull HVAC Panel Off  
And Unplug

Remove (2) Screws

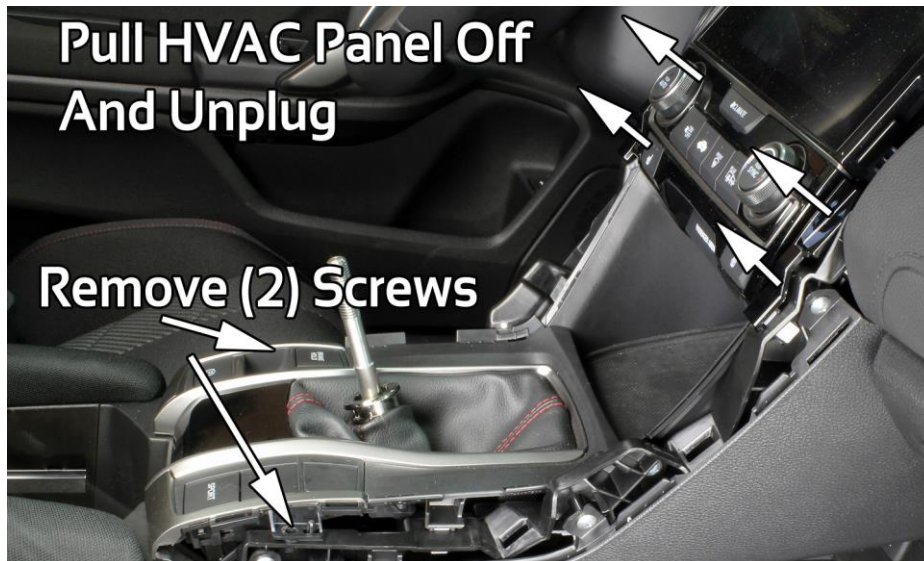



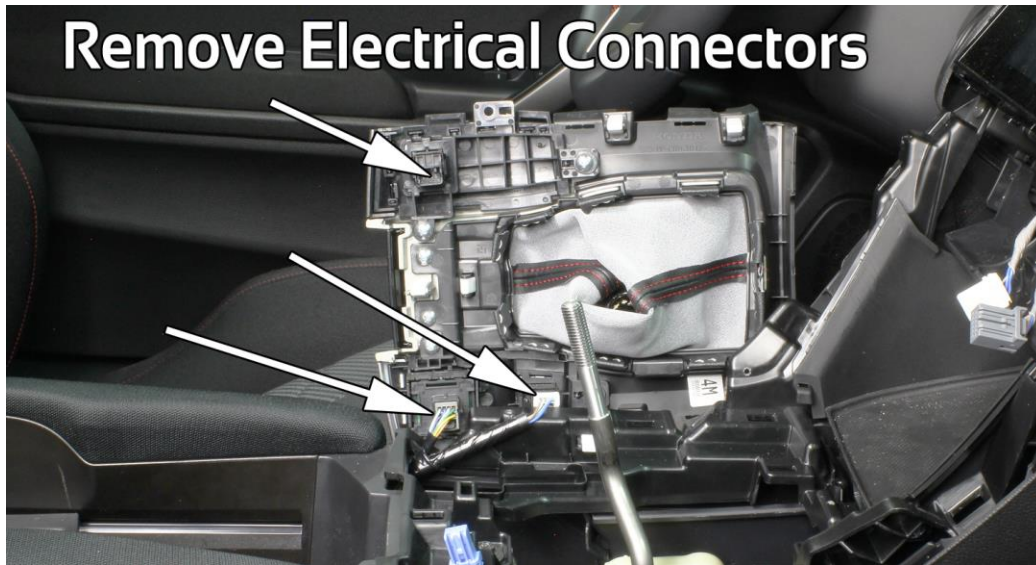

- 8) Pull shift boot and trim ring up from console and unplug any electrical connections found. See picture below showing typical Civic Si shift boot trim ring.
- 9) Remove screw in center of console as shown, then remove entire upper portion of center console from car. Take care in removing panel from around shifter as this can be a bit tricky.

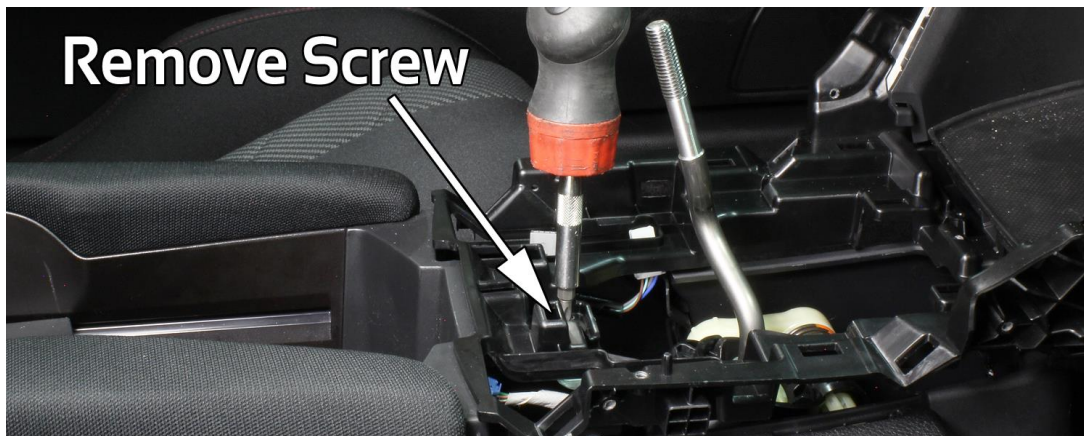

- 10) Remove USB and power port panel by pulling from the bottom of sides then out. Unplug connectors and remove panel from console.
- 11) Pull straight up on lower panel and remove from car. **NOTE: This is done to aid in removal of center console in next step.**

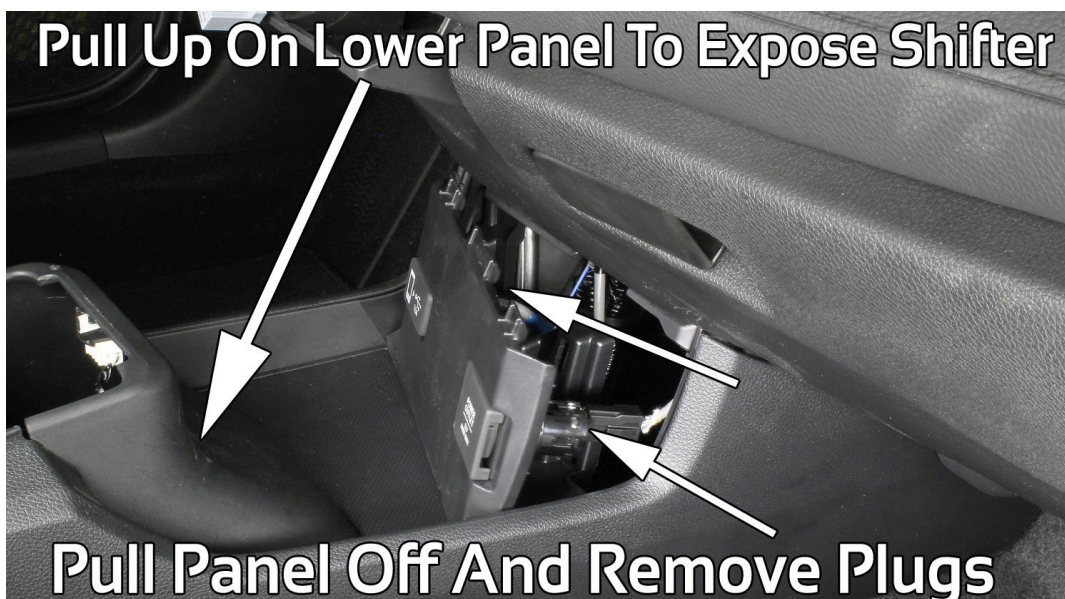

- 12) Lift up on rear of console and pull toward rear of car to free from dash. Follow all wire harnesses to each clip that secures them to the console and remove using pliers or panel popper tool. Take note of each clip so the harness can be reinstalled into the correct location during installation. This step is important to reduce any chance of rattles occurring after installation is complete.



- 13) Remove console from car. Take care to get it over the shifter and not scratching any of the plastic trim pieces.



- 14) Locate (2) bolts securing steel bracket behind shifter base and remove from car.



- 15) Locate and remove clip holding shifter cable to OEM shifter rod/bushing. Pull cable off of bushing.



- 16) Reinstall clip to shifter cable as shown above.  
17) Install all included o-rings over shifter cable and slide them all toward the front of the car. **NOTE: Some stretching will be required to get the over the larger end of the cable.**  
18) Snap cable back onto bushing and pull straight down to ensure cable is held onto bushing securely.  
19) Locate and remove small steel retaining clip securing left shifter cable to plastic pivot arm. Slide shifter cable off pivot roughly 1/4". Do not completely remove until after next step. This is important to ensure damage to cable does not occur.

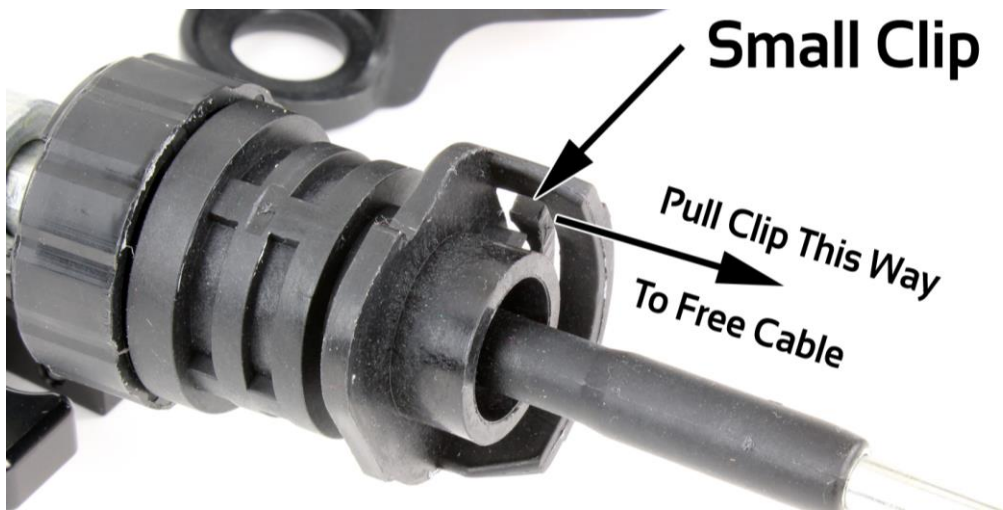

- 20) Locate small plastic clip securing left shifter cable to housing, as shown above. Pull clip toward back of car, while twisting cable counter clockwise. If done properly, cable will rotate roughly 90 degree and be able to slide out from housing.
- 21) Install ALTA shifter cable lockdown as shown making sure to push down and toward the direction as shown below.
- 22) Tighten set screws hand tight until part is held in place.

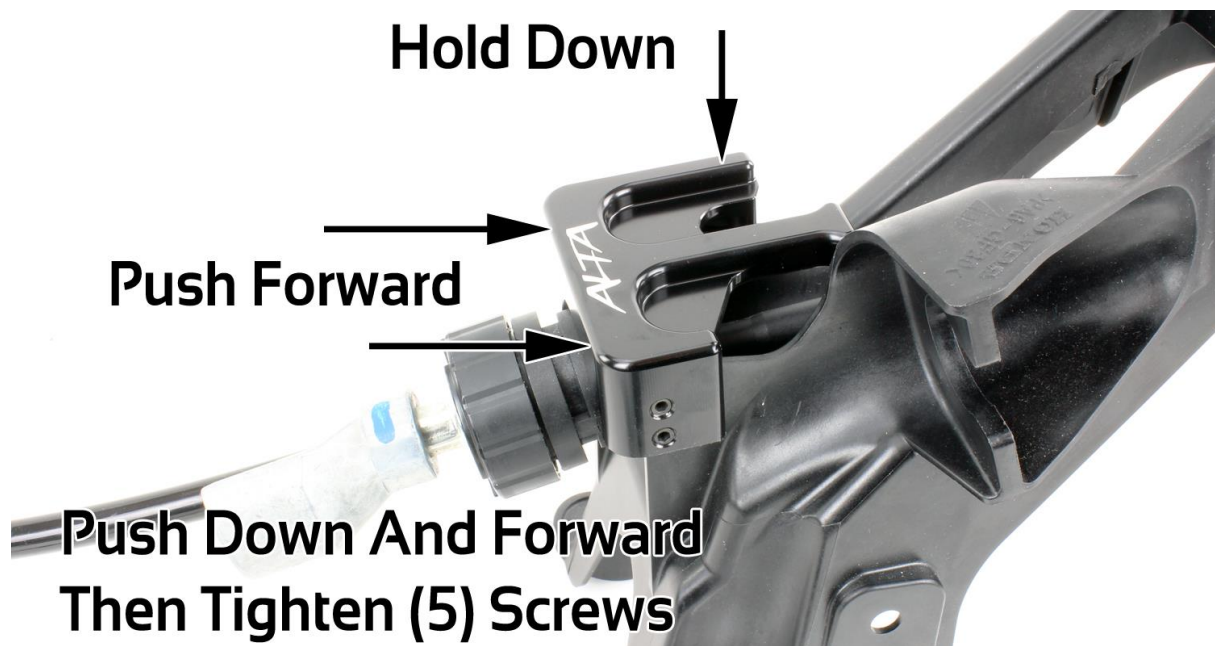



- 23) If done correctly, set screws will dig into the housing as shown in locations below, marked in green. This is important to note because if set screws do not contact these surfaces, the ALTA Shifter Cable Lockdown could move over time. If you are concerned about how the ALTA Shifter Cable Lockdown is aligned, remove part and take note of where set screws were hitting, then reinstall.

## If Installed Correctly Set Screws Will Contact Housing As Shown

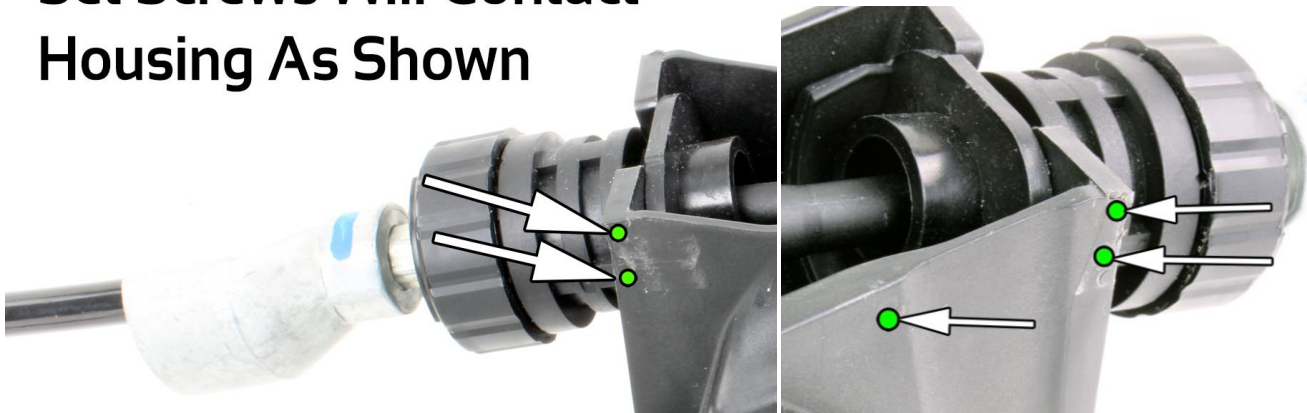

Left side of shifter housing shown above.

Right side of shifter housing shown above.

- 24) Slide all o-rings onto ALTA Shifter Cable Lockdown top as shown below. Make sure they are aligned more toward the larger end and hang straight down to cable versus angled back one way or another.



- 25) Reinstall left shifter cable over pivot arm into housing in one step. Pre-twist the cable counter clock-wise, slide it into the slot on housing then rotate clock-wise until it clicks into place. Double check it is secure by rotating cable back and forth. If secure, it should only rotate a couple of degrees.
- 26) Reinstall small metal clip to secure shifter cable to pivot arm.
- 27) Reinstall shift knob temporarily and shift through the gears to make sure there is no binding and or new clicking noises that occur.
- 28) Reinstall all parts in the reverse order, making sure to reattach wire harnesses along the way as these can rattle and make noise if not secured.

Questions, Comments and Suggestions Contact: [Tech@ALTAperformance.com](mailto:Tech@ALTAperformance.com)  
Visit Our Website for Instant Chat Options at <http://www.ALTAperformance.com>  
Call Our Tech Team at 503-693-1702